

EB1353

TERMINOLOGY FOR FOREST LANDOWNERS

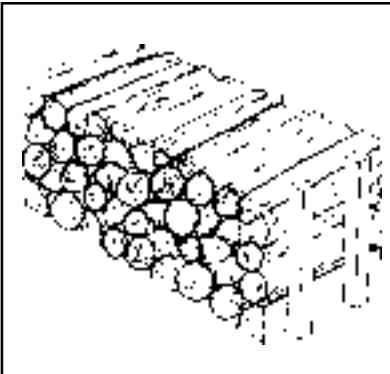

DONALD P. HANLEY, DAVID M. BAUMGARTNER, AND LEILA CHARBONNEAU

TERMINOLOGY FOR FOREST LANDOWNERS

DONALD P. HANLEY, DAVID M. BAUMGARTNER, AND LEILA CHARBONNEAU¹

INTRODUCTION

We prepared this reference bulletin primarily for forest landowners. We hope it will help owners, foresters, and loggers communicate effectively. Poor communication often results in undesirable management practices. We included forestry terms commonly used in Washington.

ABIOTIC

Nonliving components of the environment such as air, rocks, soil particles, and plant litter.

ACRE

A land area of 43,560 square feet. An acre can be any shape. If square, it would measure approximately 209 feet per side.

ADAPTIVE MANAGEMENT

A process for ecosystem management that allows for continual change as more information becomes available on resource conditions and the effects of management actions on resources.

¹Originally published in April 1987, by Donald P. Hanley, Donald R. White, David L. Adams, and David M. Baumgartner. Illustrations by Mark Woods, WSU Extension graphic designer. Revised by Donald P. Hanley, Ph.D., WSU Extension forester, Seattle; David M. Baumgartner, Ph.D., WSU Extension forester, Pullman; and Leila Charbonneau, research editor, University of Washington College of Forest Resources, Seattle.





Advanced reproduction

ADVANCED REPRODUCTION

Young trees established before a regeneration cutting.

AERIAL LOGGING

Removal of logs from a harvest area by helicopter.

AGE CLASS

All trees in a stand within a given age interval, usually 10 or 20 years.

ALLOWABLE CUT

The maximum volume of wood that can be harvested during a given period, usually equal to the forest's net growth.

ANADROMOUS

Migratory behavior of fish, such as salmon, that mature in the sea but return to fresh water to spawn.

ANNUAL GROWTH

The yearly increase in wood volume, usually expressed in terms of board feet or cubic feet per acre.

ANNUAL RING

Bands which show tree growth for one year, as viewed on the cross section of a stem, branch, or root, or on a trunk core sample. Can be counted to determine a tree's age. Variation in width of rings records how the tree responded to growing conditions in different years.



Annual ring

AQUATIC ECOSYSTEM

A water-based system of living organisms interacting with their environment.

AQUIFER

A stratum of earth or permeable rock that stores significant quantities of water. A confined aquifer is sealed above and underlain below by impermeable material.

ARTIFICIAL REGENERATION

Revegetating an area by broadcast seeding or by planting seedlings or sprouts.

ASPECT

The compass direction which a slope faces.

AUM

Animal unit month. The amount of forage required by a mature cow (or other grazing animal) and her calf for one month.

AUTECOLOGY

Ecology dealing with biological relations between a species, or individual organism, and its environment.

BARE LAND VALUE

Exclusive of improvements or standing timber value.

BARK BEETLE

An insect that bores into and beneath tree bark to lay its eggs. The feeding trails (galleries) girdle the tree and may kill it. Specific types of bark beetles attack different tree species. Most bark beetles can kill weakened trees.

BASAL AREA

A key descriptive measure of trees and stands that indicates site occupancy. For a tree, it is the cross-sectional area of the trunk at breast height (4.5 feet above ground). The basal area of a tree 14 inches in diameter at breast height (DBH) is approximately 1 square foot. Basal area per acre is the sum of basal areas of the individual trees on an acre. A stand of 100 14-inch DBH trees would contain about 100 square feet of basal area per acre.

BIOLOGICAL CONTROL

Controlling plants, diseases, and animal pests by the use of natural enemies; or inhibiting the reproduction of pests by methods that result in the laying of infertile eggs, etc.

BIOLOGICAL DIVERSITY

Richness and abundance of species, and variety of natural communities, in a forest environment. Both the number of species and the number of individuals of each species are important in considering the extent of biological diversity in an area. Also referred to as biodiversity.

BIOMASS

The total quantity (weight) of biological matter in a unit area, including all living organisms above and below ground; or the total quantity of one or more species in a unit area. Tree biomass components include wood, bark, foliage, roots, etc., of a single tree or of all the trees in a specified area.

BIOTA

The plants and animals of a given region, or period, considered collectively.

BIOTIC

Having to do with the living components of an ecosystem.

BLOW-DOWN

Uprooted trees as a result of high wind.

BLUE STAIN

A fungal discoloration, carried by bark beetles, common in pines.

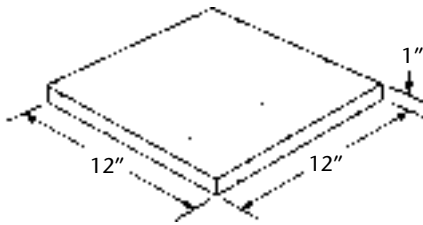

Board foot

BOARD FOOT

A unit for measuring wood volumes equaling 144 cubic inches, commonly used to measure and express the amount of wood in a tree, sawlog, or individual piece of lumber. For example, a piece of wood measuring 1 foot x 1 foot x 1 inch, or a piece measuring 1 foot x 2 inches x 6 inches, would contain 1 board foot of wood.

BOLE

The main tree trunk.

BOLT

A short log or a squared timber cut from a log, less than 8 feet long.

BOOMER

See Mountain beaver.

BREAST HEIGHT

Four and one-half (4.5) feet above the ground on the uphill side. Diameter is usually measured and basal area calculated at this point on the tree.

BROADCAST BURN

See Burning methods.

BROWSE

Leaves, buds, and woody stems used as food by deer, rabbits, and other animals. *Verb*: Eating of vegetation.

BRUSH

Commonly refers to undesirable shrubs and small trees.

BUCK

To cut a log into specified lengths.

BUDCAP

A piece of paper or other suitable material covering the terminal bud of a young seedling to prevent deer browse.

BUFFER

A protective strip of land or timber adjacent to an area requiring attention or protection. For example, a protective strip of unharvested timber along a stream.

BROADCAST BURN

A controlled fire (prescribed fire) used to burn slash without piling it.

PRESCRIBED BURN

The application of fire to a designated area under conditions of weather, soil moisture, and time of day that will accomplish specific silvicultural, wildlife, grazing, or fire-hazard-reduction purposes.

BUTT

The base of a tree or log.

CABLE LOGGING

Transfer of logs from the stump to landings by use of suspended steel cables. *See also* Skyline logging.

CAMBIUM

The growing layer of cells beneath the bark of a tree.

CANDIDATE SPECIES

Plants and animals being considered for listing as federally endangered or threatened species in the United States.

CANOPY

The uppermost layer in a forest, formed collectively by tree crowns.

CANOPY LAYERS

Forests with varying age classes may have several height classes. For example, an overstory canopy layer of trees overtopping a lower canopy of other trees or shrubs.

CARPENTER ANTS

Large black ants that tunnel into dead wood. Along with other insects, they are essential for recycling woody debris on the forest floor. These ants can be detrimental to structural wood in buildings.

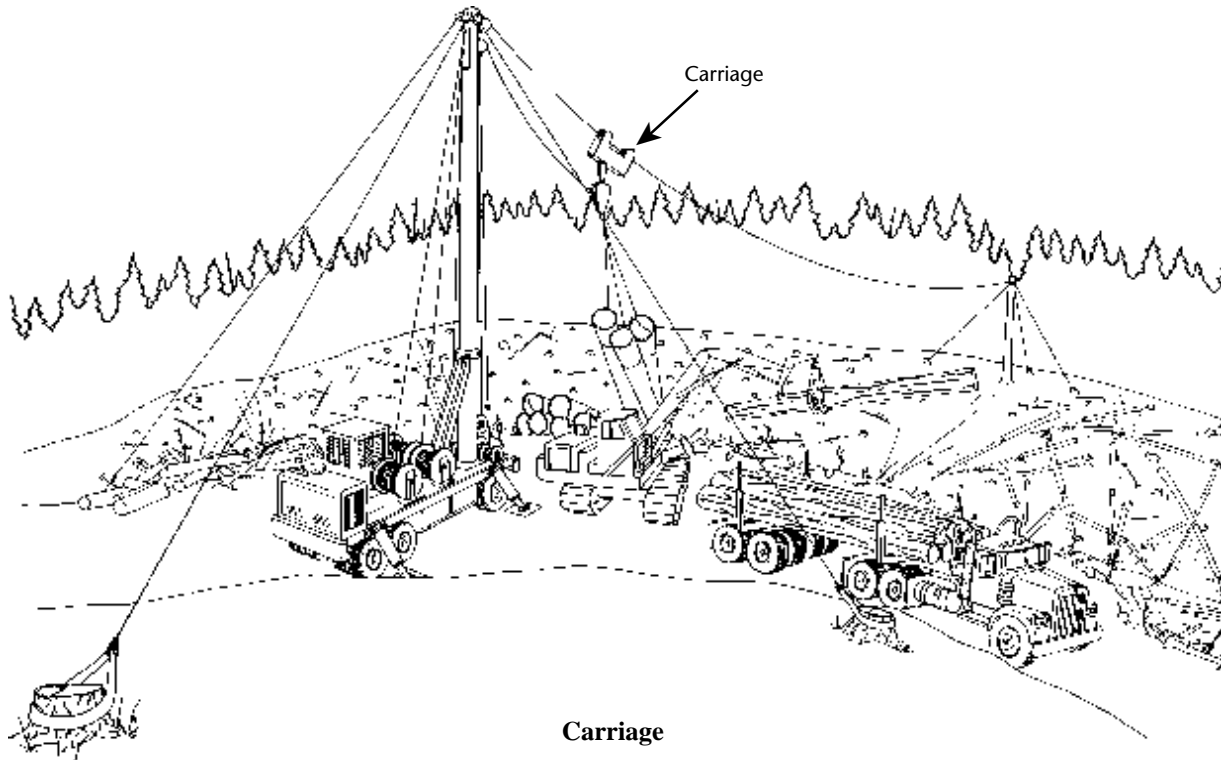

CARRIAGE

In logging, a load-carrying device with cable systems from which logs are suspended for yarding or loading.



Catface

CATFACE

A wound on a tree or log usually caused by sideswiping with equipment or by wildfire.

CALKS

Steel pegs in soles of heavy boots to give loggers secure footing. Also called corks.

CERTIFICATION

Compliance to one or more third-party programs to assure forest management sustainability.

CERTIFIED FORESTER

A designation by the Society of American Foresters that confirms that the forester possesses knowledge and is competent to practice forestry in a credible manner.

CHAIN

A unit for measuring distance. A chain is 66 feet. An acre contains an area equal to 10 square chains. A section of land is 80 by 80 chains square, or 640 acres.

CHECK SCALE

An estimate of the usable wood volume in a log as measured by an independent third party.

CHIPS

Small pieces of wood used for pulp, fuel, or pressed board.

CHOKER

A noose of wire rope used to skid logs.

CLEANING OR WEEDING

A precommercial practice of freeing seedlings or saplings from competition with shrubs, vines, or other ground vegetation.

CLEARCUT HARVEST

A harvest and regeneration technique removing all the trees (regardless of size) on an area in one operation. Clearcutting is commonly used with shade-intolerant species such as Douglas-fir or lodgepole pine, which require full sunlight to reproduce and grow well. Clearcutting produces an even-aged stand.

CLIMAX COMMUNITY

A relatively stable plant community which has changed through stages and has dominant plant populations suited to the environment.

CLINOMETER

An instrument for measuring vertical angles or slopes; usually hand-held and pocket-sized.

COARSE WOODY DEBRIS

Organic debris that IS the result of management activity, such as tree tops, large branches, and bole segments, left on-site to decay. This debris often provides wildlife habitat for small forest floor mammals and amphibians.

CODOMINANT TREES

Trees whose crowns form the general level of the stand, receiving full light from above but comparatively little from the sides. *See also* Crown class.

COLD DECK

A pile of logs left for later transportation.

COMMERCIAL CUTTING

Cutting trees that are merchantable. *See also* Harvesting methods.

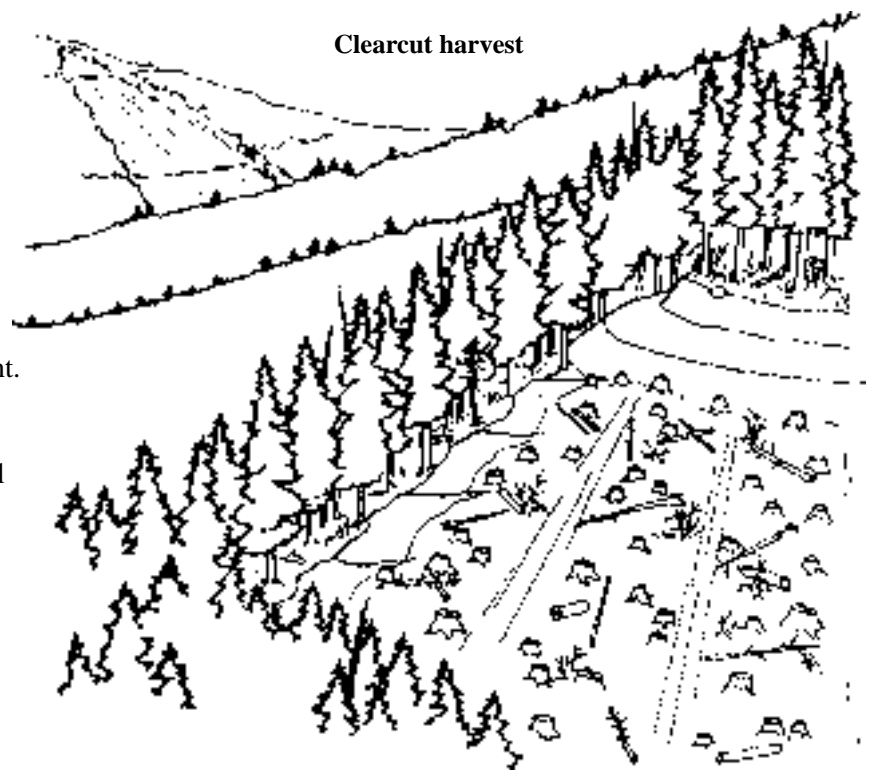



Conk

COMMUNITY

An assemblage of different organisms living and functioning together in a particular area. Usually named for the dominant plants, animals, or major physical components of the area.

COMPETITION

In a forest, the struggle for water and light among neighboring trees having similar requirements.

CONE

The female reproductive part of conifers. This structure has overlapping scales that cover the seeds.

CONIFER

A cone-bearing tree with needles, such as pine, spruce, fir, and larch.

CONK

A hard, spore-bearing structure of a wood-destrating fungus which projects beyond the bark of a tree.

CONNECTIVITY

Condition of ecosystem integrity allowing natural processes to work across a landscape without discontinuity. *See also* Corridors; Fragmentation.

CONSERVATION

The protection, improvement, and wise use of the natural environment (such as the forests, soils, and water systems) to prevent destruction and exploitation while still producing goods and services for the human population.

CONSERVATION BIOLOGY

The science of diversity, scarcity, and survival of species. Deals with active management to protect and maintain genetic variety within species. Deals also with the concepts of biological diversity, sustainability and relationships between biotic and abiotic resources. *See also* Sustainability.

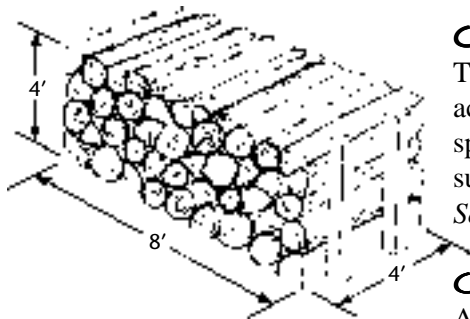

Cord

CORD

A stack of wood that has a gross volume of 128 cubic feet. A standard cord measures 4 feet x 4 feet x 8 feet, and should contain approximately 80 cubic feet of solid wood.

CORRIDORS

Generally linear strips of habitat linking isolated patches of natural habitat in the landscape. Establishment and maintenance may be actively promoted at the state and regional levels. Also, the linear area where the skyline is located, when logging with cable systems. *See also* Connectivity; Fragmentation.

COVER

Vegetation or other natural shelter serving to conceal wildlife from predators. Also refers to the protective shade vegetation provides to wildlife, fish, and the forest floor.

CRITICAL HABITAT

Specific areas within the geographic range occupied by a species listed by the federal government as endangered or threatened. The physical and biological features considered necessary for the survival and recovery of the species.

CROOK

An abrupt bend in a log—a defect.

CROP TREE

A tree identified to be grown to maturity for the final harvest cut. Usually selected on the basis of its species, its location relative to other trees, and its quality.

CROTCH

The fork of a tree or branch.

CROWN

The branches and foliage of a tree. The “live crown” refers to the living portion.

CROWN CLASS

A relative designation of tree crowns.

- **Dominant trees** are those with crowns above the general level of the canopy.
- **Codominant trees** are those with crowns forming the general level of the canopy.
- **Intermediate trees** are those with crowns below the general level of the canopy.
- **Suppressed trees** are those much shorter than the general level of the canopy.

CROWN CLOSURE

The point when, in a young stand, the crowns of the trees begin to touch each other.

CROWN DIFFERENTIATION

The process whereby some trees grow faster and develop large, full crowns, while others fall behind in height and have smaller, sparser crowns.

CROWN RATIO

A measure of the length of a tree’s live crown relative to total tree height.

CRUISE

A survey of forest land to estimate timber quantity.

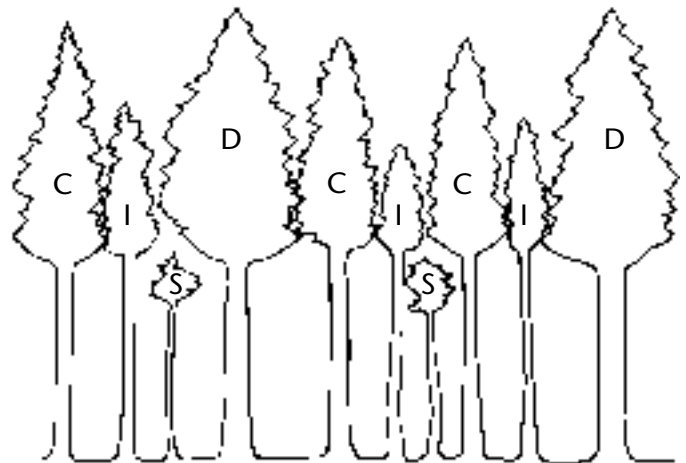
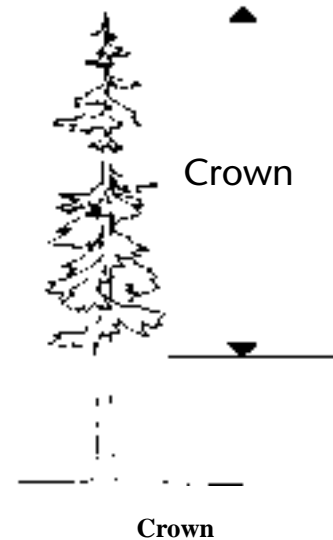

Crown class

CRUISER STICK

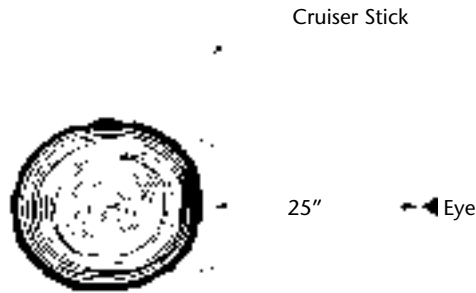

Cruiser Stick

A stick used to measure the diameter of a standing tree. The stick is held at right angles to the main trunk of the tree, and at a distance from the eye for which the stick is constructed, which is usually 25 inches.

Cruiser stick

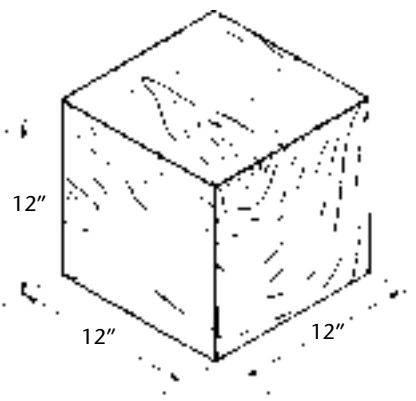

Cubic foot

CUBIC FOOT

A cube 12 inches on a side. One cubic foot of wood in a log usually produces from 3 to 7 board feet of lumber because of the cylindrical log shape and sawing losses.

CULL

A tree or log of merchantable size which, because of a defect, is useless for its intended purpose.

CUNIT

A measurement equal to 100 cubic feet of solid wood, often used in relation to pulpwood.

CUTTING AREA

A portion of the forest where timber is being cut or will be cut.

CUTTING CYCLE

The planned time interval between harvesting operations in the same uneven-aged stand. For example, a cutting cycle of 10 years in an uneven-aged stand means that a harvest cutting of trees is made every 10 years.

CUT-TO-LENGTH HARVESTER

A mechanical harvester that bucks and limbs trees into logs throughout the forest or at the landing.

DBH

The tree diameter at breast height (4.5 feet above the ground on the uphill side).

DECIDUOUS TREE

A tree that loses its leaves or needles during the fall and winter.

DECK

A pile of logs ready for loading and transporting.

DECOMPOSITION

The breaking down of dead organic matter by decay organisms.

DEFECT

That portion of a tree or log that makes it unusable for the intended solid wood product. Defects include rot, crookedness, cavities, and cracks. Severe defects cause the log to be classified as a cull.

DEFOLIATORS

Insects that feed on foliage.

DENDROLOGY

The study of tree identification.

DENSITY

A measure of site occupancy. The quantity of trees per unit of area. Usually expressed as trees/acre.

DESERTIFICATION

The process of desert expansion caused by loss of soil and vegetative cover through climate change, overgrazing, or other influences.

DIAMETER LIMIT

The smallest (but occasionally the largest) size to which trees or logs are to be measured, cut, or used. Usually refers to the stump, breast height, or top diameter.

DIAMETER-LIMIT CUTTING

A harvest based on cutting all trees in the stand over a specified diameter, regardless of tree vigor, species, or spatial distribution. Usually results in the long-term degradation of the stand.

DIAMETER TAPE

A measuring tape used to directly determine tree diameter when stretched around the circumference of the tree stem.

D.I.B.

Diameter inside the bark. Used in log scaling.

DIBBLE BAR

A flat or round metal tool used to make a hole for planting containerized seedlings.

DIRECT SEEDING

Sowing tree seed directly to forest soil to regenerate a forest.

DISTURBANCE

A natural or human-caused event, such as a timber harvest, forest fire, disruptive wind storm, or insect infestation, that alters the structure and composition of an ecosystem.

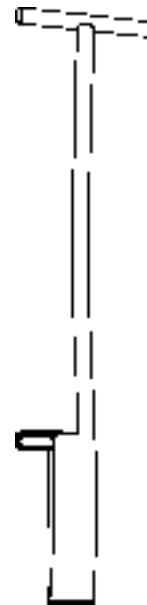

Dibble bar

DISTURBANCE MANAGEMENT

Managing disturbance events and effects, such as insects and fire, to approximate natural conditions.

DOMINANT TREES

See Crown class.

DORMANCY

A biological process in which a plant ceases most growth activities and simply maintains existing tissue.

D-PLUS (D+) RULE

A “rule of thumb” in thinning to estimate desired spacing between trees. Add a given number to the average DBH of a stand of trees, then state the number in feet. For example, a “D + 4” rule would mean that a stand with trees averaging 16 inches in diameter would need 16 + 4, or 20 feet, of growing space between trees.

DRY ROT

A wood decay caused by a specialized fungus. The term implies that wood will rot when dry, which is *not* true.

DUFF

Various stages of decaying organic matter found on the soil surface.

ECOSYSTEM MANAGEMENT

A type of natural resource management that considers the relationships between all organisms, including humans, and their environment.

ECOLOGY

The science that studies the interaction of plants and animals with their environment.

ECOSYSTEM

Ecological system. An interacting system of living organisms and their environment. The dynamic relationships of living (biotic) and nonliving (abiotic) components of a region, forest, stand, or smaller area, as well as the forces, such as weather and wildfire, that affect them.

ECOSYSTEM HEALTH

A measure of the overall capacity of an ecosystem to maintain biological diversity, normal productivity, sustainability, and resilience to disturbance.

ECOSYSTEM SUSTAINABILITY

See Sustainability.

ECOTONE

A transitional area between two forest or rangeland communities containing the characteristic species of each as well as characteristics of its own. A point of abrupt change, such as a prairie-forest junction or a land-water interface.

EDAPHIC

Of the soil or influenced by the soil rather than by climatic factors, especially pertaining to living organisms.

EDGE EFFECT

The tendency toward greater species variety and greater density of animal and plant life in the margin where two ecological communities meet. *See also* Ecotone.

EMPHASIS AREA CONCEPT

An alternative to reserve areas and buffer zones that integrates neighboring land uses and protects the emphasized use through disturbance management.

ENDANGERED SPECIES

A plant or animal vulnerable to extinction in all or a significant portion of its range. Identified by the Secretary of the Interior in accordance with the Endangered Species Act (1973).

ENDEMIC POPULATION LEVEL

A normal (insect) population level. Commonly used with insect populations.

ENTOMOLOGY

The study of insects and their environments. *See also* Forest entomology.

ENVIRONMENT

The external conditions, both physical and biological, in which an organism lives. Includes climate, soil, topography, food supply, and all other influences affecting development.

ENVIRONMENTAL IMPACT STATEMENT (EIS)

A document evaluating the probable consequences of a proposed project that might significantly alter the environment. Required by the National Environmental Policy Act (1969) for any such project a U.S. government agency plans to undertake, regulate, or fund. An EIS is released in draft form (DEIS) to other agencies and the public for comment and review.

EPHEMERAL STREAM

A stream that flows only sporadically, such as after storms.

EPIDEMIC

Widespread insect or disease incidence beyond normal proportions.

EVEN-AGED MANAGEMENT

Stand management designed to remove (harvest) all trees at one time, or over a short period, to produce even-aged stands. Most trees are within 20 years of the same age.

EVERGREEN TREE

A tree that retains some or most of its leaves, or needles, throughout the year.

EXOTIC SPECIES

A nonnative plant or animal species introduced by humans, either deliberately or accidentally.

EXTINCT

Said of a species or other taxonomic group having no living members.

FALLER

A logger who specializes in felling trees. Also called “cutter” or “sawyer.”

FIREBREAK

An existing barrier, or one constructed before a fire occurs, from which all or most flammable materials have been removed.

FIRE CYCLE

The average time between fires in a given area.

FIRE SCAR

An injury or wound on the stem of a tree caused or accentuated by fire.

FORAGE VALUE

The relative importance of plants for grazing purposes.

FOREST

A plant community dominated by trees and other woody plants.

FOREST ENTOMOLOGY

The science that deals with insects in forest trees or products.

FORESTER

A professional who has been educated in forestry at a college or university.

FOREST MANAGEMENT

The application of scientific, economic, and social principles to managing a forest property for specific objectives.

FOREST PRACTICE

A specialized law that is intended to foster the protection of public resources, such as air, water, and wildlife, from adverse affects of forest management activities.

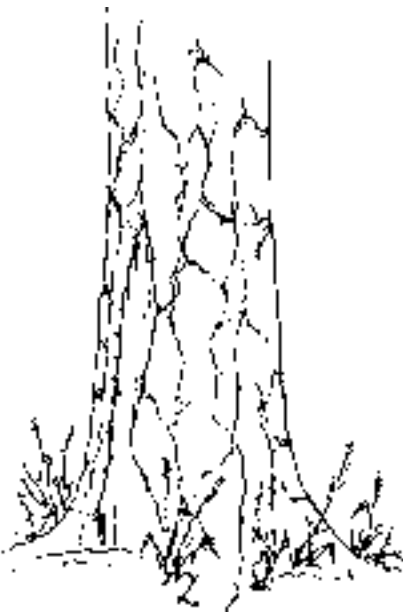

Fire scar

FOREST PATHOLOGY

The science that deals with diseases of forest trees.

FOREST PLAN

A document that guides all natural resource management activity and establishes management standards and guidelines for a National Forest, embodying the provisions of the National Forest Management Act (1976).

FOREST PRACTICES ACT

Washington State legislation designed to protect public resources such as water and wildlife, from effects of indiscriminate management practices. All forest operations on private lands must comply with regulations administered by state forestry personnel.

FORESTRY

The science, art, and practice of managing and protecting tree and forest resources for human benefit.

FOREST TYPE

A group of tree species which, because of their environmental requirements, commonly grow together. Examples of forest types are the Douglas-fir/hemlock type or the spruce/fir type. Also, a descriptive term used to group stands with similar composition and development characteristics.

FORM CLASS

A measure of bole taper derived by dividing diameter inside bark at a given height (usually 17.3 or 33.6 feet) by DBH, times 100. These values often are entered when using tree-volume tables.

FORTY

A square land tract of 40 acres, usually 20 chains on a side.

FORWARDER

A specialized vehicle that moves logs from the forest to the landing for loading onto logging trucks. Commonly used with cut-to-length harvesters.

FRAGMENTATION

The breaking up of a large forest area into patches either by natural processes or through management or conversion to other land uses. Natural habitats may become separated into isolated segments or “islands.” *See also* Connectivity.

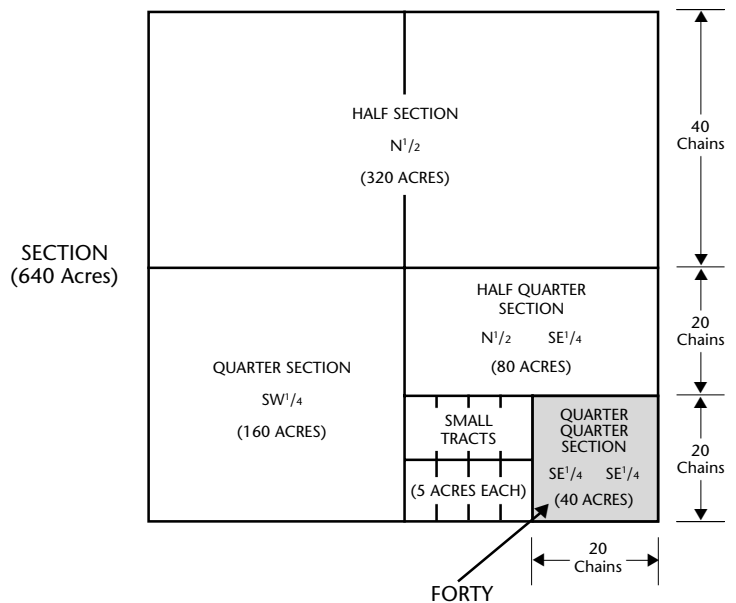

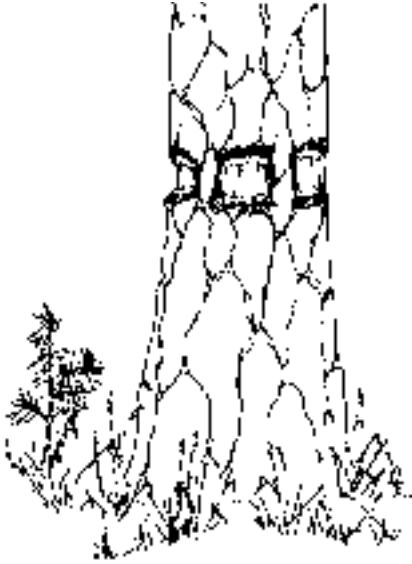

Frill

FRILL

A V-shaped cut through the bark and cambial tissues of the tree—used as a place to apply herbicides.

FROST CRACK

A longitudinal tree bark split caused by freezing sap. Usually found on thin-barked trees.

FUEL LADDER

Lower limbs along the bole of a tree that allow ground fire to “climb” into the tree crown.

FUNGI

Any group of organisms that live in the soil and decompose dead organic matter.

GALLERY

A passage or burrow which bark beetles have excavated in the cambium of a tree for feeding or egg-laying purposes.

GIRDLING

A cutting or insect gallery that completely encircles the tree trunk. Girdling usually results in the death of the tree.

GIS

Geographic Information System. A computer database designed to store and retrieve geographic information linked to topographic or land features.

GRADING

Evaluating and sorting trees, logs, or lumber according to quality.

GROW-MAT

Specialized fabric material placed around newly planted seedlings to inhibit weed competition and promote initial seedling growth. Also known as “fabric-mulch.”

GROWING STOCK

All the trees growing in a stand, generally expressed in terms of number, basal area, or volume.

GYPPO

An independent logger who usually works on a contract basis. Gyppo is not a derogatory term.

HABITAT

The local environment in which a plant or animal naturally lives and develops.



Gallery

HABITAT TYPE

Classification of a land area according to dominant plant forms (usually trees and shrubs) and physical characteristics. Can help to indicate the biological potential of a site.

HARDWOOD

A term describing broadleaf trees, usually deciduous, such as oaks, maples, cottonwood, ashes, alders, and elms.

HARVEST

Removing trees on an area to obtain an income or usable product.

HARVESTING METHODS

See Clearcut harvest; Seed-tree harvest; Selection harvest; Shelterwood harvest.

HAULBACK LINE

In cable logging, the line used to pull chokers or the carriage from the landing out to the felling area.

HAZARD REDUCTION OR SLASH REDUCTION

The burning, crushing, or scattering of slash to reduce the risk of forest fires or forest fire damage to an area.

HEART ROT

A decay in trees, characteristically confined to the heartwood. It usually originates in the living tree.

HEARTWOOD

The inner core of a woody stem, wholly composed of nonliving cells and usually differentiated from the outer enveloping layer (sapwood) by its darker color.

HEEL-IN

To store seedlings before planting by placing them in a trench and covering the roots with soil.

HEIGHT

- **Merchantable height.** Tree height (or length of the tree trunk) up to which a particular product may be obtained. For example, if 6-inch minimum diameter sawlogs were being cut from the tree, its merchantable height would be its height up from the stump to a diameter of 6 inches. The products being cut determine merchantable height.
- **Total height.** Tree height from ground level to top.

HERBICIDE

Chemical labeled by the U.S. EPA for killing or controlling plants.

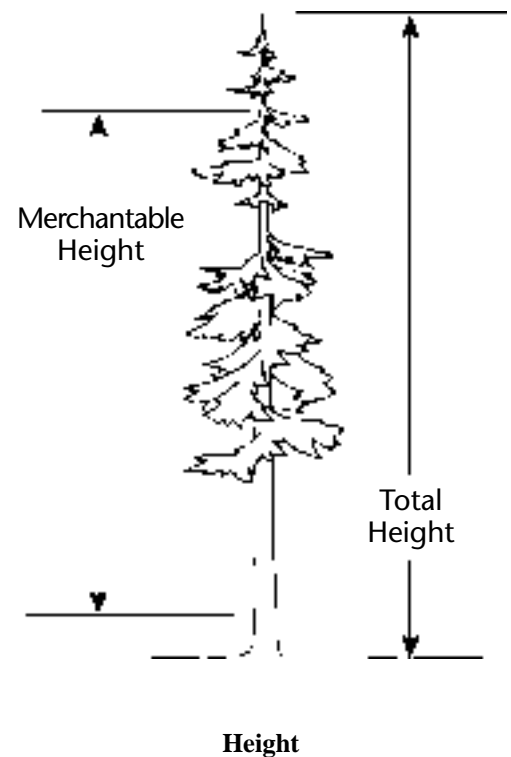

HIGH-GRADING

A harvesting technique that removes only the best trees to obtain high, short-term financial returns at the long-term expense of remaining stand growth potential. *See also* Diameter-limit cutting.

HIGH-LEAD LOGGING

A system that uses cables rigged to a spar high above the ground to lift logs during yarding. *See also* cable logging.

HOG

A machine used to reduce waste pieces of lumber and slabs, or small tree stems, to chip form.

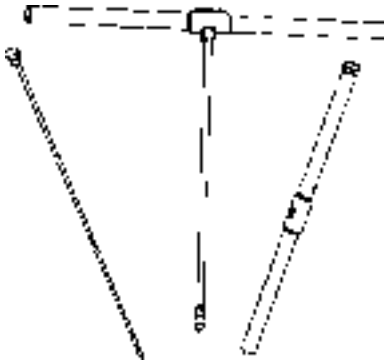

Increment borer

HOME RANGE

The area within which the activities of an animal are confined. The boundaries may be marked, such as by scent, and also may be defended, depending on the species.

INCREMENT

See Annual growth.

INCREMENT BORER

A hollow, augerlike instrument used to bore into a tree trunk to remove a cylindrical cross section (core sample) of wood. It is used to expose annual growth rings.

INDICATOR SPECIES

A plant or animal species whose presence in an area indicates that certain specific habitat conditions prevail throughout the area.

INSECTICIDE

A chemical registered by the U.S. EPA to kill insects.

INTEGRATED PEST MANAGEMENT (IPM)

A method that evaluates alternatives for managing forest pest populations on the basis of pest-host and pest-environment relationships.

INTEGRATED RESOURCE MANAGEMENT

A term used to indicate the simultaneous consideration of ecological, physical, economic, and social aspects of lands, waters, and resources in developing and carrying out multiple-use, sustained-yield management.

INTERMEDIATE CUT

Removing immature trees between stand establishment and stand harvest to improve the quality or reduce competition among remaining trees. In contrast to a harvest cut, an intermediate cut may or may not generate income.

INTERMEDIATE TREES

See Crown class.

INTOLERANT SPECIES

Tree or shrub species that are incapable of establishing or growing in the shade of other trees or shrubs.

INVASIVE SPECIES

An insect, plant, or mammal that has expanded its range, often to the detriment of native species.

KERF

Width of a cut made by a saw.

LANDING

A place where logs are assembled and loaded on trucks for transport to mills.

LANDSCAPE

A large land area composed of interacting groups of ecosystems, including all the physical and biological aspects of such an area regardless of ownership.

LANDSCAPE CONNECTIVITY

See Connectivity.

LANDSCAPE ECOLOGY

The study of biological interactions across a large land area, or watershed.

LEADER

The growing top (terminal shoot) of a tree.

LEAVE TREES

Trees left standing by design after a harvest or thinning.

LIBERATION CUTTING, ALSO KNOWN AS RELEASE CUTTING

An operation to release young trees from overtopping *older* trees.

LITTER

The uppermost layer of the soil, made up of freshly fallen or slightly decomposed organic materials. *See* also Duff.

LOG

A piece of the woody stem of a tree, usually cut to a specified length.

LOGGER

A person whose occupation is harvesting timber. Some loggers are educated in scientific forestry principles either from formal classroom education, or as part of certification programs.

LOGGING COST

The total cost of felling, bucking, skidding, loading, and hauling associated with forest harvesting.

LOGGING RESIDUE

See Slash.

LOG RULE

A table that expresses log volume based on log diameter and length. The Scribner Decimal C Rule is the legal rule in Washington State and is expressed in board feet.

LOG SCALE

The lumber content of a log as determined by a log rule.

LOP

To chop or saw branches, tops, or small trees after fellings. These pieces, or debris, are usually left on the ground to decompose.

MACROCLIMATE

The climate of a large region as a whole, considered apart from modifying irregularities of land and vegetation. *See also* Microclimate.

MAINLINE

In cable logging, the line used to retrieve logs. *See also* Skyline logging. Also the main access road to a forest area.

MANAGEMENT PLAN

A written plan for the organized handling and operation of a forest property. It usually includes data and practices designed to provide optimum use of forest resources according to the landowner's objectives.

MARKING TIMBER

Selecting and indicating, usually by painting, trees to be cut or retained in a harvesting operation.

MATURE FOREST

In an ecological sense: A mature forest possesses varied biological diversity throughout the ecosystem.

MATURE TREE

A tree in a managed forest that has reached the size or age for its intended use.

MBF

Abbreviation for thousand board feet.

MEAN ANNUAL INCREMENT (MAI)

The annual increase in size (volume) of a tree. Or the increase in size (volume) of a stand at a certain age, divided by that age in years.

MENSURATION

That phase of forestry dealing with the measurement of volume, growth, and development of individual trees and stands.

MERCHANTABLE

The part of a tree that can be manufactured into a salable wood product.
See also Height.

MICROCLIMATE

The climate of a small, specific area reflecting such local differences as soil surfaces, vegetation, and atmospheric characteristics.

MICROSITE

An environmental feature that is small in scale but unique in character. Microsites often have a significant impact on natural regeneration.

MISTLETOE

A parasitic plant causing growth reduction and deformities on trees.

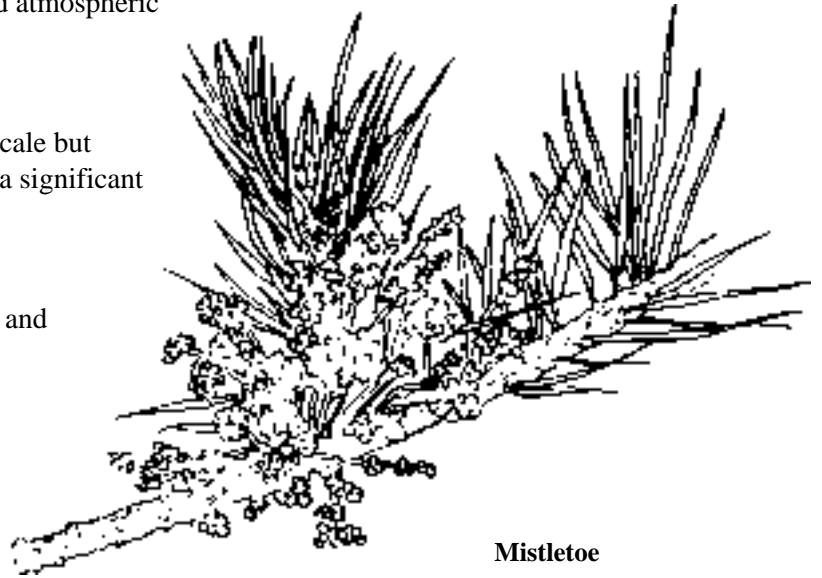

Mistletoe

MMBF

Abbreviation for million board feet.

MORTALITY

Death of forest trees as a result of competition, disease, insect damage, drought, wind, fire, air pollution, and other factors.

MOUNTAIN BEAVER

(*Aplodontia rufa*) A small nocturnal rodent, found throughout the Coast Range and western Cascades in Oregon and Washington. This burrowing animal girdles Douglas-fir seedlings. Also called a boomer.

MULTIPLE USE

Forest land management for more than one purpose, such as wood production, water, wildlife, recreation, forage, and aesthetics.

MULTI-STORIED

Forest stands containing trees of different heights.

MYCORRHIZAL FUNGI

Fungi that form a symbiotic relationship with the roots of many shrubs and certain trees, enabling those trees to extract more water and nutrients from the soil.

NATURAL REGENERATION

Trees established as a result of natural seeding.

NEEDLE CAST

Premature browning and dropping of needles caused by a fungus.

NET PRESENT VALUE (NPV)

The maximum dollar amount that can be invested without reducing the rate of return below a specified interest rate. Reflects the magnitude of investment as well as the flow of benefits and costs over time. Sometimes called present net value (PNV).

NONCOMMERCIAL CUTTING

Cutting trees to improve growth conditions of the stand. Trees cut in this operation do not yield a net income, usually because the trees cut are too small to be marketable.

NUTRIENTS

Chemical substances necessary for plant and tree growth.

NUTRIENT CYCLING

The biological, geological, and chemical circulation of inorganic elements such as nitrogen, phosphorus, and potassium through the soil, living organisms, water, and air, thus providing nutrients to animals and vegetation in the process.

OBLIGATE SPECIES

A species restricted to a particular environment or a particular mode of life, such as a plant or animal found only in a narrowly defined habitat, e.g., a tree cavity.

OLD GROWTH

A forest ecosystem containing old trees, usually over 150 years old, and associated plants and wildlife characterized by diverse structure including gaps filled by shade-tolerant species.

ORGANIC MATTER

Material produced by plants and animals, such as leaves, branches, bark, wood, hair, fur, and bones.

OVERRUN

The excess lumber sawn from logs over the estimated volume or log scale, usually expressed in percent of log scale.

OVERSTOCKED

A stand or forest condition, indicating more trees than desired.

OVERSTORY

That portion of the trees in a stand forming the upper crown cover.

PARTIAL CUT

Any cutting scheme that removes less than the total tree stand at any one time.

PATHOLOGY

The science that deals with diseases of forest trees, forest stands, and products.

PEAVEY

A long-handled tool with a spike point and hinged hook; used to roll logs.

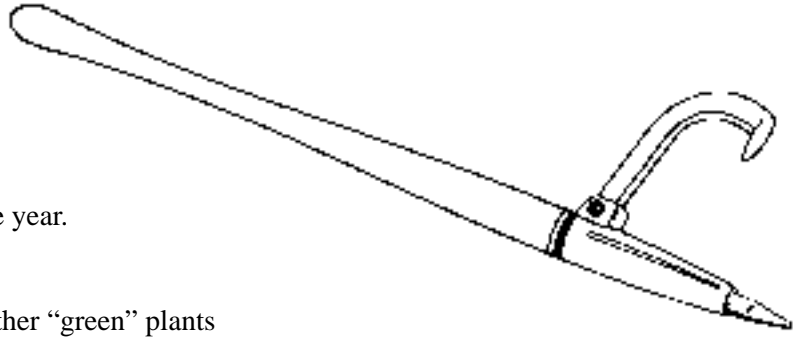

Peavey

PERRENIAL STREAM

Stream that flows water throughout the year.

PHOTOSYNTHESIS

The chlorophyll process in trees and other “green” plants changing carbon dioxide and water into carbohydrate using the sun’s energy.

PILE AND BURN

A controlled burn where slash is concentrated, usually by machinery, before burning.

PIONEERS

Shade intolerant species that are the first trees to invade freshly disturbed sites, such as red alder or western larch.

PISTOL BUTT

Bases of trees curving downslope and then upward. This may indicate unstable or moving soil (or sliding snow).



Pistol butt

PITCH

Resin occurring in the wood of certain conifers.

PITCH-OUT

A defense mechanism of vigorous trees against insects, whereby a flow of pitch pushes bark beetles back out their entry holes through the bark.

PLANT ASSOCIATION

A vegetation community, in which the dominant species forms the highest level in the hierarchy of plant species. *See also* Climax community.

PLANTATION

A reforested area established by planting trees.

PLANTING BAR

A hand tool used to plant seedlings.

PLANTING STOCK

Seedling trees ready for planting.

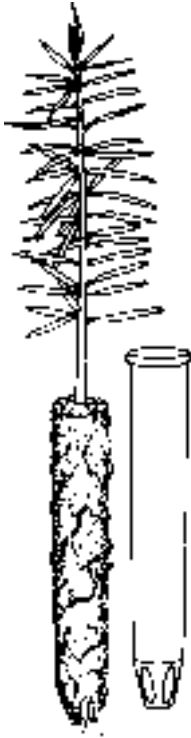

Plug seedling

PLUG SEEDLING

A seedling tree grown in a small container, under carefully controlled environmental conditions, such as in a greenhouse. Seedlings are removed from containers for planting. Also called containerized seedling.

POLE SAW

A saw attached to a long pole for pruning without using a ladder.

POLE STAND

A stand of trees whose diameters range from approximately 5 to 9 inches.

POPULATION

Organisms (trees, shrubs, herbs, animals, insects, etc.) of common ancestry that occupy a particular forest area.

PREBUNCH

In logging, to collect logs or other material at intermediate staging areas in preparation for the main yarding operation.

PRESCRIBED FIRE

See Burning methods.

PRESCRIPTION

A management action to cause orderly change in a forest.

PRESENT NET VALUE

See Net present value (NPV).

PRESERVATION

- *As applied to wood.* Treating wood products with chemicals to prevent damage by insects or decay.
- *In reference to land and resources.* Maintaining a natural environment undisturbed by human influence.

PROVENANCE

The geographical source or place of tree seed origin.

PRUNING

Removing live or dead branches from standing trees to improve wood quality.

PULPWOOD

Wood cut primarily for the manufacture of paper, fiberboard, or other wood fiber products. Dead trees often are cut for this purpose.

PUNKY

A soft, weak, often spongy condition in wood; caused by decay.

RANGELAND

A large open land area on which livestock wander and graze. The native vegetation is mainly grasses, forbs, and shrubs.

REFORESTATION

Reestablishing a forest on an area where forest vegetation has been removed.

REFUGE

To save, rather than manage, portions of an ecosystem or forest.

REGENERATION CUTTING

A harvesting technique that provides for stand regeneration, such as clearcutting, seed-tree, selection, and shelterwood cutting methods.

RELEASE CUTTING

Improving the species composition in young stands by cutting inferior species. This operation releases the better trees from competition.

RELIEF CULVERT

A structure that relieves surface runoff from roadside ditches. Prevents volume and velocity of runoff from reaching excessive buildup.

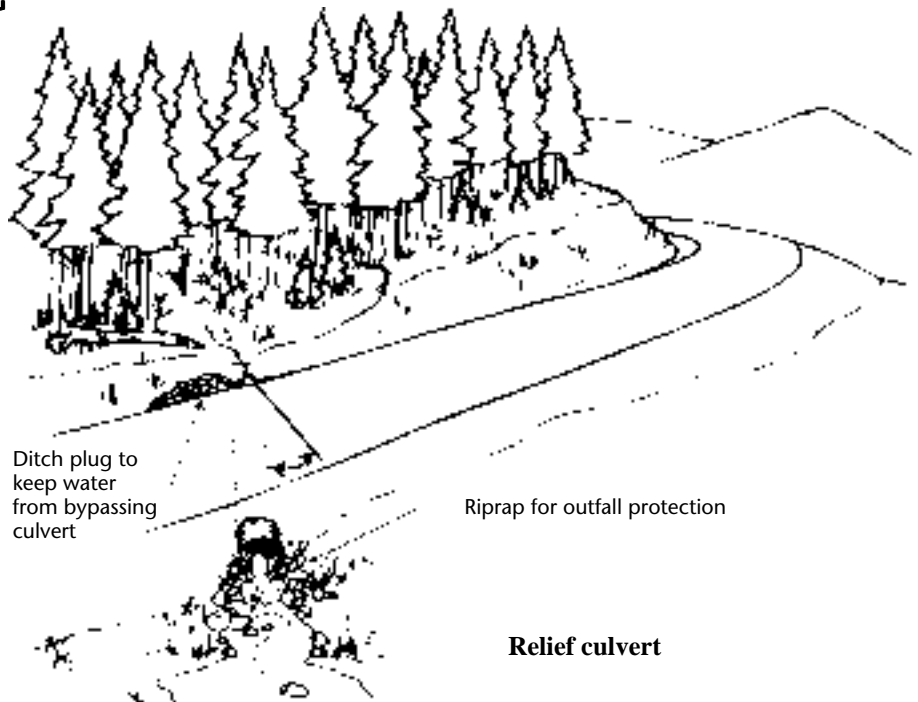

REPRODUCTION

Young trees. Also the process of forest replacement or renewal, which may be introduced artificially by planting, or naturally by sprouting or self-seeding.

RESIDUAL

Trees left in a stand, after cutting, to grow until the next harvest.

RESILIENCE

The ability of a forest ecosystem to recover from a disturbance.

RIPARIAN

Pertaining to the area along the banks of a river, stream, or lake.

RIPARIAN ECOSYSTEM

An ecosystem that is transitional between land and water ecosystems. The soils, plants, animals, and other organisms found in such an area.

RODENTICIDE

Any chemical labeled by the U.S. EPA used for killing rodents.

ROOT COLLAR

On a tree, the transition zone between stem and root. Usually recognizable in trees and seedlings by a slight swelling.

ROOTS

That portion of a tree, generally underground, which anchors the tree and absorbs water and nutrients from the soil.

ROT

Wood in a state of decay.

ROTATION AGE

The number of years required to establish and grow trees to a specified size, product, or condition of maturity. Rotation ages vary from 7–10 years for intensively managed plantations to over 100 years for extensively managed stands.

ROUNDWOOD

Wood products which are round, such as pulpwood, posts, pilings, utility poles, and fencing materials.

SALVAGE CUT

Harvesting damaged or defective trees for their economic value.

SANITATION CUT

Harvesting trees that are infected by, or highly susceptible to, insects or diseases, to protect the rest of the forest.

SAPLING

A small tree, usually between 1 and 3 inches DBH, and 15 to 30 feet in height.

SAPWOOD

The light-colored, actively growing section of the tree, between the heartwood and the bark. Serves to conduct water and minerals to the crown.

SAWLOG

A log large enough to produce a sawn product—usually at least 10 inches in diameter.

SCALE STICK

A flat stick, similar to a yardstick, calibrated so log volumes (usually in board feet) can be read directly when the stick is placed on the small end of a standard-length log.

SCALING

Estimating the usable wood volume in a log, following fundamental rules.

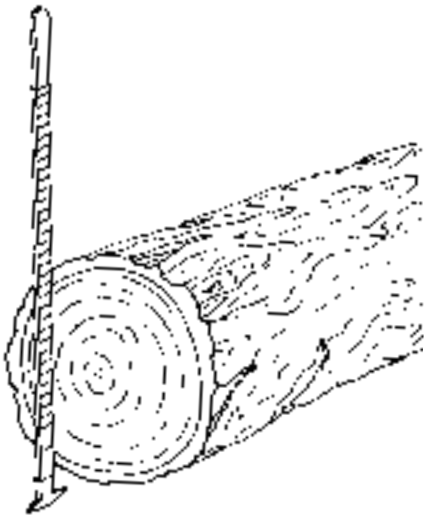

Scale stick

SCALPING

Physically removing the sod or surface layer of debris, exposing mineral soil for tree planting.

SCARIFY

To disturb the forest floor and topsoil in preparation for natural regeneration, direct seeding, or planting.

SECOND GROWTH

Young forests that originated naturally or were planted on the site of a previous stand which was removed by cutting, fire, or other cause.

SECTION

A surveyed parcel of land containing 640 acres—one square mile.

SEEDLING

A tree, usually less than an inch in diameter, and no more than 3 feet in height, which has grown from a seed (in contrast to a sprout). Also refers to nursery-grown trees that have not been moved in the nursery to obtain more growing space. *See also* Transplant.

SEED-TREE HARVEST

Removing nearly all trees from a harvest area at one time, but leaving a few scattered trees to provide seed for a new forest stand. Usually 5 to 10 trees per acre are retained. These are removed later, after sufficient regeneration is established.

SEED YEAR

A year in which a given species produces a large seed crop. Used in reference to trees that produce seed irregularly or infrequently.

SEED ZONE

Areas which have similar climate and elevation conditions. Used to specify where tree seed was collected and where trees from such seed will probably grow successfully.

SELECTION HARVEST

Harvesting individual trees or small groups (group selection) of trees at periodic intervals (usually 8 to 15 years) based primarily on their vigor and age. Selection harvesting perpetuates an uneven-aged stand.



Seed-tree harvest

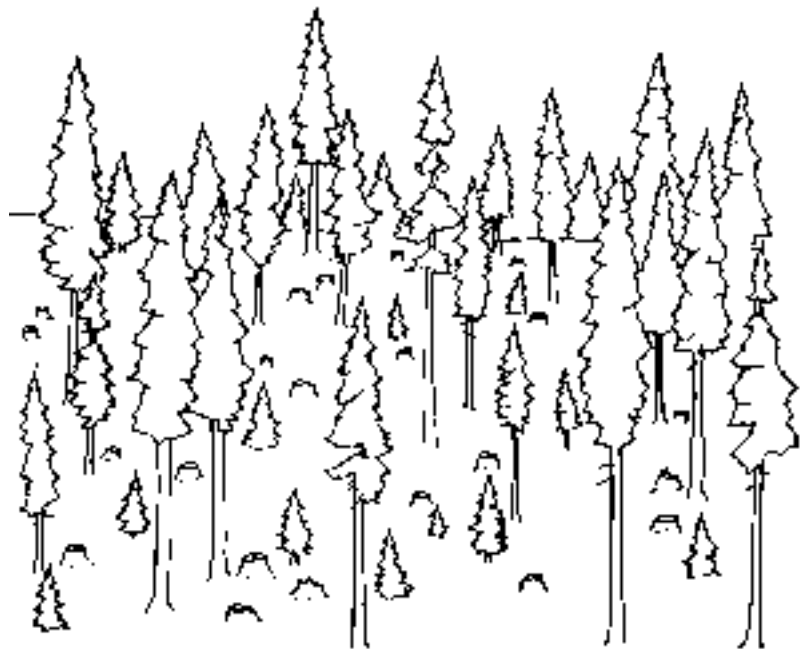

Selection harvest

SELECTIVE LOGGING

Removing only desirable species or trees over a certain diameter, also known as diameter limit cutting. Over time, it can result in a stand composed of poorly formed, slow growing trees.

SERAL STAGE

A phase of ecological development toward a more mature or climax community. *See also* Climax community; Successional stage.

SEROTINOUS CONES

Cones that remain closed after maturity. Lodgepole pine cones open after being exposed to intense heat. This mechanism ensures seed production following a fire.

SHADE INTOLERANT

A term applied to trees or shrubs that grow and reproduce better in direct sunlight than in the shade of other trees or shrubs. The opposite of shade tolerant. Tree examples include coastal Douglas-fir, western larch, lodgepole pine, and red alder.

SHADE TOLERANCE

The capacity to develop and grow in the shade of, and in competition with, other trees and shrubs. Examples of highly shade-tolerant tree species are western hemlock, western red cedar, and Pacific yew.

SHEAR

To sever a tree with a knifelike mechanical tool. Also to trim back and shape tree branches, making foliage dense and giving the tree a conical form. Usual treatment for Christmas trees.

SHEAR HEAD

A mechanical device that pinches trees off at the stump.

SHELTERWOOD HARVEST

Harvesting trees in a series of two or more operations. New seedlings grow and become established in the partial shade protection of older trees. Harvests are usually 5 to 10 years apart, yielding an even-aged stand.

SHRUB

A low-growing perennial plant with a woody stem and low branching habit.

SILVICULTURE

The art, science, and practice of establishing, tending, and reproducing forest stands with desired characteristics, based on knowledge of species characteristics and environmental requirements.

Shelterwood harvest

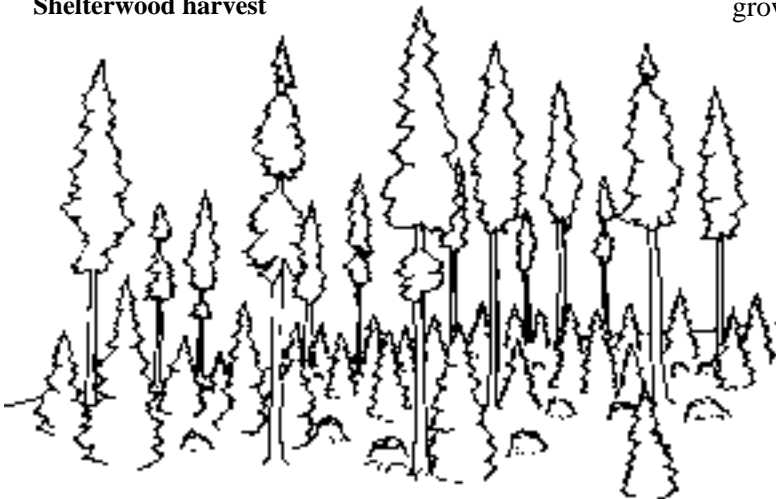

SITE

An area evaluated for its capacity to produce forest products. Evaluation is based on combined biological, climatic, and soil factors.

SITE CLASS

A grouping of similar sites that indicates relative productivity. The common system for the Douglas-fir region includes five site classes, in which Site I is the most productive and Site V is the least productive.

SITE INDEX

An expression of forest site quality based on the height of the dominant and codominant trees in the stand at a specified age, usually 50 or 100 years.

SITE PREPARATION

Preparing an area of land for forest establishment. Methods used may include clearing, chemical vegetation control, or burning.

SKIDDING

Pulling logs with equipment or horses from the stump to the landing.

SKID TRAIL

A road or trail over which horses or equipment drag logs from the stump to a landing.

SKYLINE LOGGING

A logging method in which a traversing block or carriage rides on a skyline or cable. The line itself does not move; it is attached to a donkey drum or an anchorage at the landing, and to a tail tree or tail hold on the far end.

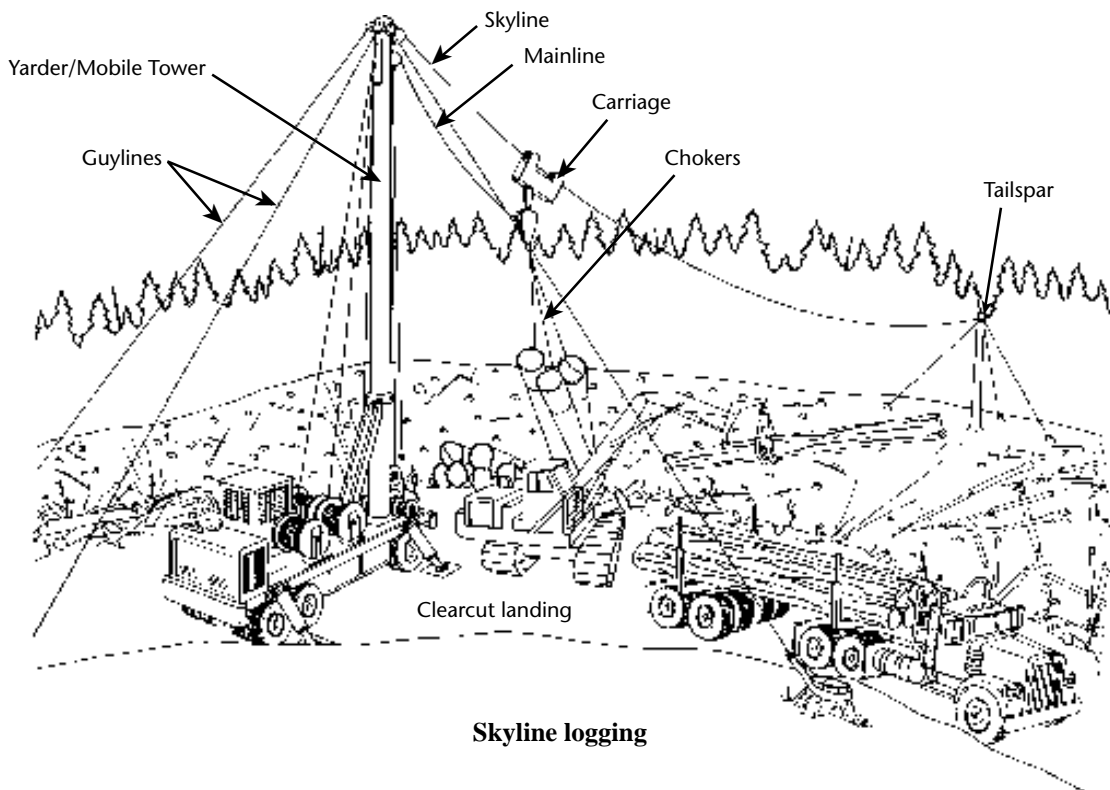

Skyline logging

SLASH

Nonmerchantable residue left on the ground after logging, thinning, or other forest operations. Includes tree tops, broken branches, uprooted stumps, defective logs, and bark. Slash can have certain ecological benefits, such as adding nutrients to the soil or providing wildlife habitat.

SLOPE

The incline of the terrain usually expressed as the amount of incline in feet over a hundred feet of horizontal distance.

SMOKE MANAGEMENT

Conducting a prescribed fire under suitable environmental conditions to keep the impact of smoke within designated limits. *See also* Burning methods.

SNAG

A standing dead tree.

SOCIOECONOMIC

Combining social and economic considerations.

SOIL COMPACTION

The process by which soil particles are squeezed or compressed, reducing air and water spaces.

SOIL pH

A measure of the acidity of the soil. Seven is neutral, less than seven is acidic, and greater than seven is alkaline.

SOIL TEXTURE

Proportion of clay, silt, and sand in soil.

SPAR

A portable tower used in cable logging to provide lift when yarding.

SPECIES

A group of organisms (plants or animals) that are very similar in appearance and can interbreed freely with each other but not with other groups.

SPECIES COMPOSITION

In a forest, the mixture of tree species in a stand.

SPROUT

A stem vegetatively produced from a stump or the roots; sometimes a branch produced after the stem was formed.

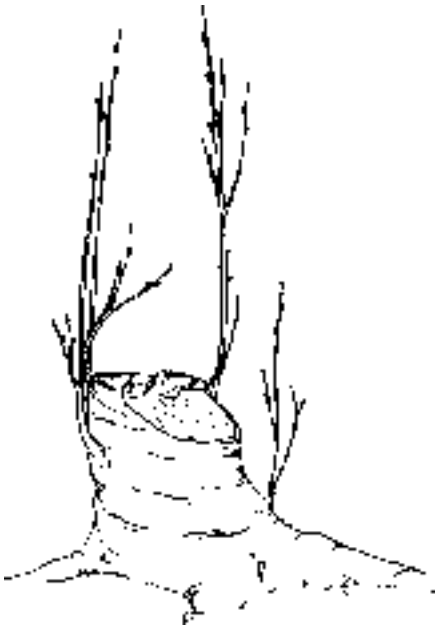

Sprout

STAND

A recognizable area of the forest that is relatively homogeneous and can be managed as a single unit. Stands are the basic management units of the forest. Stand types include:

- *All-aged*—A stand that supports trees of all ages and usually all sizes. This stand type is rare. Contrast it with an even-aged stand.
- *Even-aged*—A stand in which trees are essentially the same age (within 10 to 20 years).
- *Fully stocked*—A stand where trees effectively occupy all growing space, yet ample room exists for developing crop trees.
- *Mixed*—A stand that has more than one species in the main tree canopy.
- *Over mature*—A stand of trees that is older than normal *economic* rotation age for the type.
- *Overstocked*—A stand that is overcrowded, thus reducing tree vigor.
- *Pole*—A stand in which the dominant trees are 5 to 9 inches in diameter.
- *Pure*—A stand in which at least 80% of the trees belong to a single species.
- *Residual*—The stand which remains after cutting.
- *Sawtimber*—Most trees in the stand are large enough in diameter (usually 10 to 12 inches DBH or larger) to be sawn into lumber.
- *Understocked*—A stand in which crop trees do not effectively occupy the growing space.
- *Uneven-aged*—A stand that supports trees of several age classes (technically, more than two age classes).

STAND DENSITY

A quantitative measure of stand stocking, or the number of trees for a given area.

STAND STRUCTURE

A descriptive term to express the “fullness” of the ecosystem with living organisms, such as trees, shrubs, and forest floor species. Stand structure is defined in terms of both horizontal and vertical richness.

STAND TABLE

A table by diameter classes of volume, basal area, or trees per acre existing in a stand or expected to exist at a certain time.

STEWARDSHIP

The responsibility to manage forest land with practical wisdom.

STOCK TYPE

The age and growing condition of a seedling, usually expressed by a number (such as 1 + 0 or 1 + 1), designating the number of years that the seedling was grown in a seedbed and then in a transplant bed.

STOCKING

A description of the number of trees, basal area, or volume per acre in a stand compared with a desirable level for best growth and management. Often stocking is used as a relative term, such as partially stocked, normally stocked, or overstocked.

STOMATA

Small openings that allow moisture within the leaves and/or needles to escape, in a process called transpiration.

STRIP CUT

A clearcut laid out as a long, narrow strip.

STUD LOG

A small log, usually 4 to 8 inches top DIB and 8 feet long usually cut into 2 x 4s.

STUMPAGE VALUE

The monetary value of a tree or group of trees as they stand in the woods uncut (on the stump). Often this value is paid as a delivered log price *less* logging and transportation costs.

SUCCESSION

The replacement of one plant community by another, which may end in a climax community; Plant association.

SUCCESSIONAL STAGE

A phase in the natural development of forest communities. Over time, favorable conditions are reached for the establishment of the next stage. Commonly used stages include stand initiation, stem exclusion, under-story reinitiation, and old-growth. *See* also Stand structure.

SUNSCALD

Bark and cambium injury caused by an increase in exposure to the sun's rays, often from thinning. Thin-barked species, such as grand fir, are the most susceptible.

"SUPER TREES"

Seedling trees grown from genetically improved seed.

SUPPRESSED TREES

Trees much shorter than the general level of the canopy.

SURFACE RUNOFF

Water that moves over the ground surface.

SUSTAINABILITY

Forest development that incorporates the means to maintain biological diversity, resilience to stress, and ecosystem health and integrity, in the context of the ability to meet future as well as present human needs.

SUSTAINED YIELD

Management of forest land to produce a relatively continuous flow of timber or revenue.

TAILSPAR OR TAIL HOLD

A tree used to anchor the mainline away from the landing in cable logging.

TAPER

The gradual diameter reduction of a tree or a log from the base to the top.

TARIFF TABLE

A tree-volume table based on DBH and total height.

TAXES²

- **Ad Valorem (general property) Tax**

A state (local) tax on accumulated wealth. Usually assessed and paid annually as a percentage of the assessed value of the property (land and improvements).

- **Estate Tax**

A federal (state) tax imposed on the right to transfer property at death. The amount of the tax is measured by the value of the property in the estate.

- **Excise (yield) Tax**

A state (local) tax paid by the harvester of standing timber. It is computed as a percentage of the gross income value of the standing timber and is imposed in lieu of the general property tax.

- **Gift Tax**

A federal (state) tax imposed on the donor's right to transfer property as a gift. The tax is payable by the donor.

- **Income Tax**

A federal (state) tax on the gross income, less operating expenses, of a taxpayer for a given accounting period. The tax is computed as a percentage of net income.

- **Inheritance Tax**

A federal (state) tax imposed on the donor's right to transfer property as a gift. The tax is payable by the donor.

²The section on taxes was authored by *B. Bruce Bare*, Professor, College of Forest Resources, University of Washington.

- **Productivity Tax**

A state (local) tax on forest land or forest land plus standing timber. The tax is based on site quality, and the capitalization of future expected timber revenues. *Bare land value* is the value of forest land used to grow and harvest continued crops of timber exclusive of the value of improvements. The value may be based on market transactions or on an estimate of the future value of timber crops produced on the land.

- **Sales Tax**

A state (local) tax paid by purchasers of final products. The tax is computed as a flat percentage of the value of the sale. The tax is levied on purchases of equipment and supplies, and on retail sales of firewood, logs, and finished products.

- **Severance (privilege) Tax**

A state (local) tax paid by the harvester of standing timber, and computed as a fixed dollar value per unit volume. The tax is imposed in addition to the general property tax.

TERRESTRIAL ECOSYSTEM

A land-based ecosystem.

THINNING

Tree removal in a forest stand that reduces tree density and tree-to-tree competition. Thinning encourages increased growth of fewer, higher quality trees. Thinning types include:

- *Commercial thinning*—Any thinning of merchantable trees.
- *Crown thinning (also high thinning or thinning from above)*—A thinning that removes the dominant and codominant trees.
- *Free thinning*—To achieve specified stand structure.
- *Low thinning (also thinning from below)*—A thinning that removes the smallest, suppressed trees.
- *Natural thinning*—A natural process where trees die as a result of root or crown competition.
- *Precommercial thinning*—Any thinning of nonmerchantable trees, often called PCT.
- *Proportional thinning*—A thinning that retains the same proportion of tree diameter classes.
- *Row thinning*—A plantation thinning that removes specific tree rows.
- *Selection thinning*—A thinning that selects and removes individual large trees.

THINNING SHOCK

A condition where trees sometimes show signs of ill health or stress after a thinning operation that opens up the stand. *See* also Sun Scald.

TIMBER STAND IMPROVEMENT (TSI)

Applying cultural practices to a young forest stand to improve the growth and form of trees and achieve a desired stocking and species composition.

TRANSPIRATION

See Stomata.

TRANSPLANT

A very young tree or seedling lifted from a nursery seedbed and replanted at the nursery.

TREE

A woody plant having a well-defined stem, usually standing over 10 feet high at maturity.

TREE FARM

A privately owned woodland in which producing timber is a major management goal. It may be recognized as a “certified tree farm” by the American Tree Farm System.

TRIM ALLOWANCE

Excess log length to allow for losses in the manufacturing process, usually 6 inches on 16-foot logs and 8 to 12 inches on 32-foot logs. Trim allowance may vary among mills.

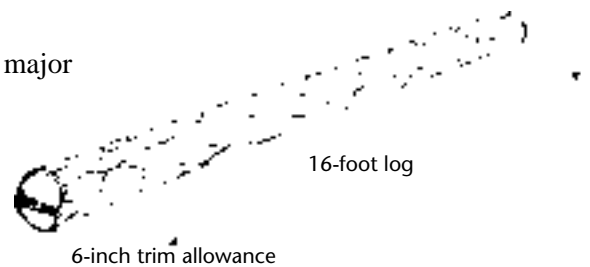

Trim allowance

TURN

The logs brought to the landing during a single yarding or skidding cycle.

TURNUP

A green branch left when harvesting a Christmas tree. This branch, turned upward, becomes the next tree.



Turnup

UNDERSTORY

That portion of the trees or other vegetation below the canopy in a forest stand.

UNEVEN-AGED MANAGEMENT

Managing a forest by periodically harvesting trees of all ages to maintain a broad age (or size) class distribution in which there are a greater number of trees in each smaller age-class than in the next older or larger class, up to some maximum age. This type of management is not common in the West. *See* also Selection harvest.

VIEW SHED

The landscape that can be seen from a particular viewpoint or along a transportation corridor.

VOLUME TABLE

A table estimating the volume of wood in a standing tree based on its diameter and merchantable height.

WATER BAR

A diagonal ditch or hump in a trail or road which diverts surface water runoff to minimize soil movement and erosion.

WATERSHED

An area of land that collects and discharges water into a single stream or other outlet. Also called a catchment or drainage basin.

WATERSHED ANALYSIS

The study of how a particular drainage network functions. An aspect of ecosystem management planning.

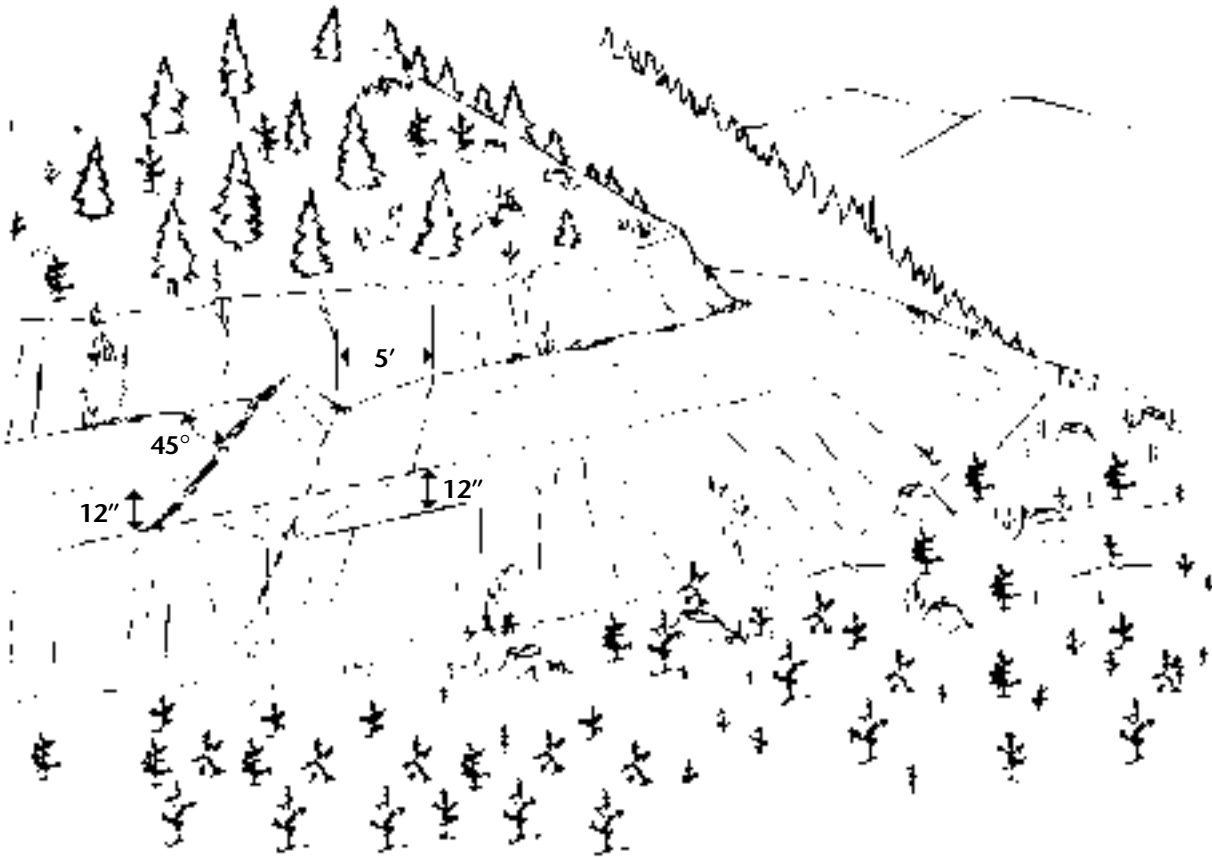

Water bar

WEED TREE

A tree of a species of little or no value to the landowners.

WETLANDS

Marshes, swamps, and other water-saturated soils that offer important habitat for wildlife, significant support of nutrient cycling in ecosystems, and protection against the severity of storms and floods. Wetlands are among the most vulnerable lands to destruction and conversion to other uses.

WIDOWMAKER

Any limb, top, leaning tree, or other material in the forest that is in danger of falling to the ground without warning, thus creating a safety hazard.

WILDLIFE HABITAT

The environmental conditions of a specific place occupied by wildlife species.

WILDLING

A seedling naturally reproduced outside of a nursery, used in forest planting.

WINDTHROW

Trees blown over or knocked down by high wind, snow, or ice.

WOLF TREE

A low-value tree occupying more space in the forest than its economic value justifies. Usually older, larger, or more branchy than other trees in the stand.

WOODLOT

The wooded portion of a farm or ranch.

YARDING

Moving logs by a cable system from the stump to a landing.

YIELD TABLE

A table predicting volume, basal area, or number of trees per acre to be found, or expected in the future, in fully stocked stands on specific sites at specified ages.

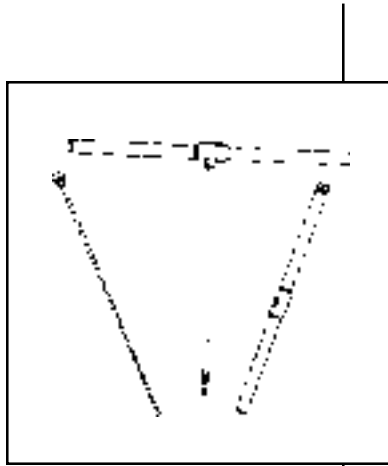

College of Agricultural, Human, and Natural Resource Sciences

WSU Extension bulletins contain material written and produced for public distribution. You may reprint written material, provided you do not use it to endorse a commercial product. Alternate formats of our educational materials are available upon request for persons with disabilities. Please contact the Information Department, College of Agricultural, Human, and Natural Resource Sciences, Washington State University for more information.

Originally published in April 1987, by Donald P. Hanley, Donald R. White, David L. Adams, and David M. Baumgartner. Illustrations by Mark Woods, WSU Extension Graphic Designer. Revised by Donald P. Hanley, Ph.D., Washington State University Extension Forester, Seattle; David M. Baumgartner, Ph.D., Washington State University Extension Forester, Pullman; and Leila Charbonneau, Research Editor, University of Washington College of Forest Resources, Seattle.

Issued by Washington State University Extension and the U.S. Department of Agriculture in furtherance of the Acts of May 8 and June 30, 1914. WSU Extension programs and policies are consistent with federal and state laws and regulations on nondiscrimination regarding race, sex, religion, age, color, creed, national or ethnic origin; physical, mental, or sensory disability; marital status, sexual orientation, and status as a Vietnam-era or disabled veteran. Evidence of noncompliance may be reported through your local WSU Extension office. Trade names have been used to simplify information; no endorsement is intended. Revised February 2006. Subject code 400.

EB1353